

Visual Signalling

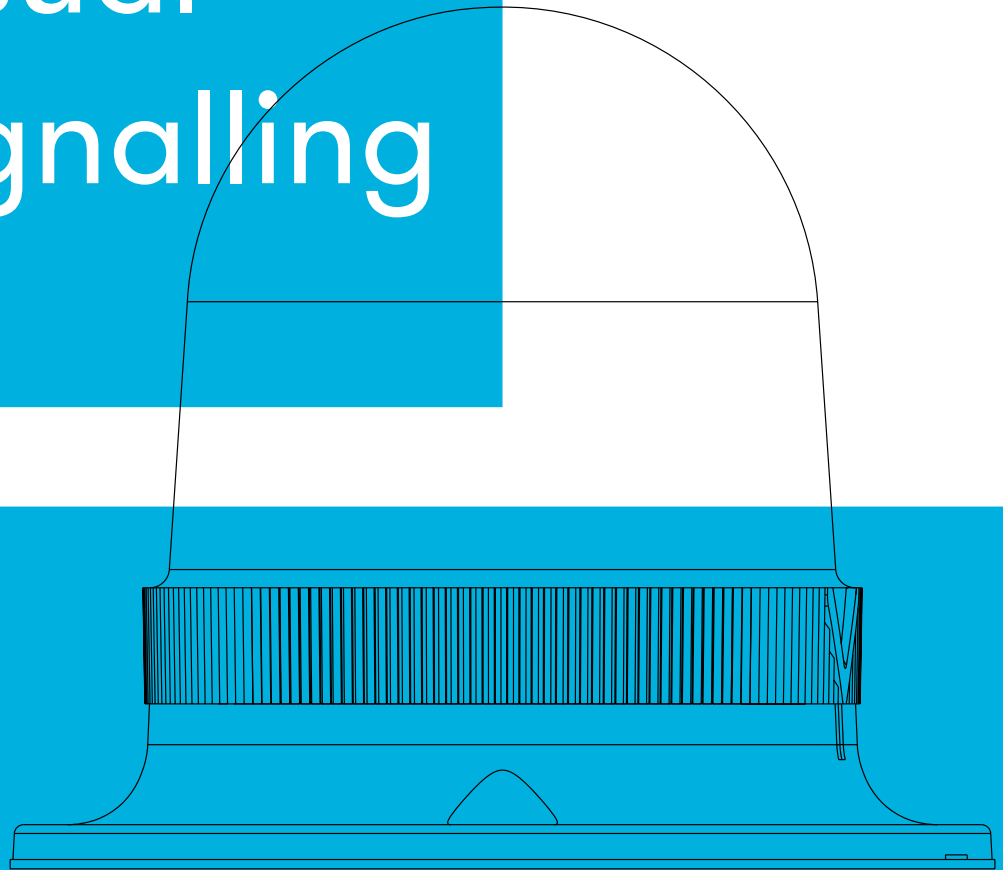

Series R

Market Launch April 2020/HMI fair

The LED-Design-
Powerhouse



PRODUCTS

RDC	led steady beacon
RDM	led multi-function beacon
RDMHP	led multi-function beacon High Performance
RMM	led multi-colour beacon
RCDM	compact led multi-function beacon
RCMM	compact led multi-colour beacon

ARGUMENT

- leading performance and product range
- modular system – “1 size fits all”
- visual-audible solutions for all beacon models
- multi-function beacon offers 7 externally switchable operating modes (total 28 modes)
- High Performance model for applications in bright sunlight etc.
- multi-colour beacon offers 7 externally switchable colours
- stand-alone industrial beacon design
- significant reduction of order numbers nevertheless very comprehensive product range

INDUSTRY/APPLICATION

- for industrial and general applications in practically all industries
- for indoor and outdoor applications (IP66)
- electrical wholesale



Series Q

PRODUCTS

QDS / QDM	led steady/flashing beacons
-----------	-----------------------------

QBS / QBM	led multi-strobe/multi-function beacons
-----------	---

ARGUMENT

- cubic design very popular beacon range in 2 main sizes
- effective front and lateral signalling/performance
- primarily for wall mount applications
- multi-strobe beacon with 4 strobe modes + steady and flashing patterns
- for indoor and outdoor applications (IP66)
- combinable beacon/beacon and beacon/sounder assemblies (series A/Q)

INDUSTRY/APPLICATION

- for industrial and general applications in practically all industries
- for indoor and outdoor applications (IP66)
- electrical wholesale
- customized models for crane/special vehicle applications

the Bright



Series N

PRODUCTS

NES	led steady/flashing beacons
-----	-----------------------------

NFS-HP	led multi-strobe beacons
--------	--------------------------

NMS-HP	led multi-colour beacons (red-yellow-green)
--------	---

ARGUMENT

- compact led beacons with high performance leds
- switched mode power supply for wide voltage range
- for indoor and outdoor applications (IP65, IP67)
- sophisticated lens design for optimal signalling effect
- comprehensive mounting options

INDUSTRY/APPLICATION

- for industrial and general applications in practically all industries
- customized models for crane/special vehicle applications

the Performer



Series T+U

PRODUCTS

TDC / UDC led steady/flashing beacons

TDF / UDF led multi-strobe beacons

TMW/UMW base for horizontal mounting

TMV/UMV base for vertical mounting

ARGUMENT

- Ø 75mm and Ø 60mm medium/ smaller size led beacons
- excellent brightness and signalling effect
- for indoor and outdoor applications (IP66)
- wide range of mounting options

INDUSTRY/APPLICATION

- for industrial and general applications in practically all industries
- electrical wholesale
- door, access and gate applications



Series P

PRODUCTS

PCH / PCL led steady/flashing beacons

PFH / PFL led multi-strobe beacons

PMH led multi-colour beacons

ARGUMENT

- Ø 75mm led beacons, pre-wired with 1m PUR cable
- high IP66/67 IP rating
- for challenging outdoor applications
- excellent brightness and signalling effect
- pre-mounted stainless steel mounting screws
- horizontal, vertical and pole mounting options

INDUSTRY/APPLICATION

- for industrial and general applications in practically all industries
- for difficult outdoor or special vehicle applications



Series M22

PRODUCTS

IBS/IBM/IBL led steady/flashing panel mount beacons

ISS/ICM/ICL led multi-strobe panel mount beacons

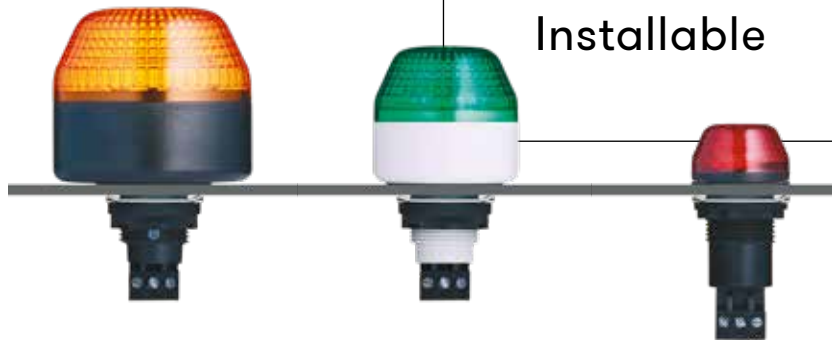

the Brightest
Installable

ARGUMENT

- Ø 30/45/65 mm led panel mount beacons
- IP65 in panel mount condition
- light functions externally switchable via terminal
- excellent front/side signalling effect
- dual and triple colour models also available
- excellent price/performance ratio

INDUSTRY/APPLICATION

- for industrial and general applications
- for switch cabinet/panels and enclosures
- for versatile applications in practically all industries

Series T+U

PRODUCTS

TDCP / UDCP led steady/flashing panel mount beacons

TDFP / UDFP led multi-strobe panel mount beacons

the Allrounder



ARGUMENT

- Ø 75/60 mm larger led panel mount beacons
- high IP66 rating in panel mount condition
- light functions externally switchable via terminal
- excellent lateral and front signalling effect
- very good price/performance ratio

INDUSTRY/APPLICATION

- for industrial and general applications
- for switch cabinet/panels and enclosures
- for gate, access control applications